

**FAN SERVICES
INCORPORATED™**

UNI-COMBUSTION FANS

**FOR SUPPLYING COMBUSTION AIR - OIL, COAL AND GAS FIRING
SERIES 1820**

FAN WHEELS AND PARTS

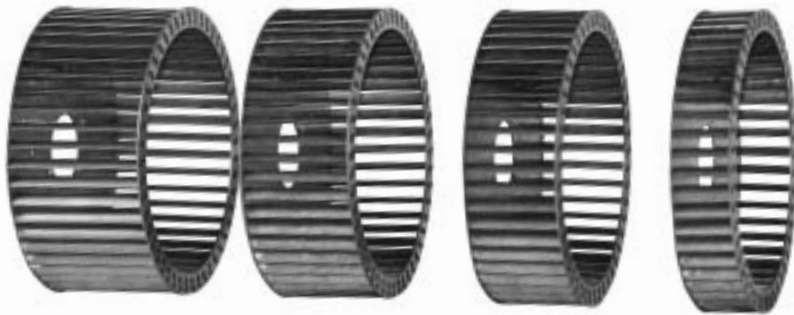

OR COMPLETE ASSEMBLIES



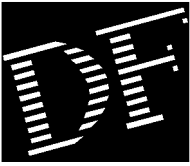

QUALITY COMPONENTS OR COMPLETE

APPLICATION

Development and perfection of uni-combustion fans stemmed from long experience in the mechanical draft field. As a result, these fans are widely preferred in packaged type equipment for supplying

combustion air for oil, gas and coal firing. Uni-Combustion fans are also used for other industrial applications, such as oven circulating fans.

FEATURES

- Heavy construction for Long Trouble-free life
- Compact, high capacity design for minimum space.
- Wide range of sizes to match exact capacity requirements.
- Vortex inlet damper control for improved volume regulation and power saving.
- Parts available for built-in installations. Complete fans with motors, available for low installation costs.
- Reliable capacity ratings.
- Standard parts stocked for quick delivery
- Custom arrangements and constructions available.

WIDE RANGE OF SIZE SELECTION

Uni-combustion fans are built in eleven basic sizes with capacities ranging from 200 to 24,000 CFM at static pressures to 10" W.G. Ratings of the basic sizes are shown in the capacity table on page 5. To match diverse volume requirements at direct connected motor speeds, many sizes are also furnished in narrow widths. Available housing widths are shown on page 6 and wheel widths on page 4. A method of computing the performance of narrow

width fans is shown in the footnote to the capacity table. Where required, and on special order, banded wheels can be furnished to reduce the effective width. When vortex control is supplied, and excess fan capacity is available, a stop can be furnished to limit the vortex control opening, thus limiting the capacity and horsepower. The above selection versatility enables the user to match nearly every performance requirements within the capacity range.

VORTEX CONTROL

Vortex inlet damper control can be supplied on all but size 1/2 and 5/8 fans for accurate and efficient volume regulation, so necessary for most combustion air installations. This device consists of movable blades mounted in the fan inlet ring and arranged to produce variable velocity of approach of the air entering the wheel. This arrangement produces volume control superior to other low cost methods, as well as increased power savings. Close regulation with vortex control is effective from specified air volume (with vortex control wide open) down to about 20% of specified volume.

Design 3

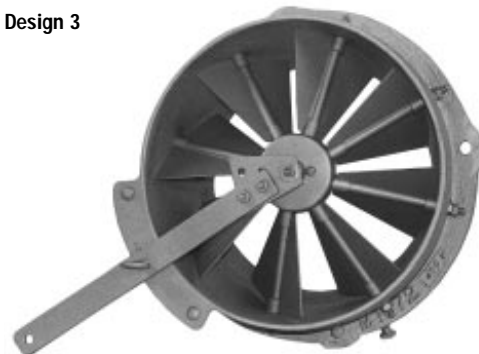

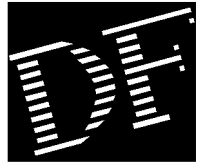

WHEELS

Uni-combustion wheels are of the centrifugal forward curved blade type which delivers maximum capacity for a given diameter with quiet operation. Sizes 1/2 through 1-3/8 have 48 blades and sizes 1-1/2 through 2 have 60 blades. Die cut tenons on blade ends for sizes 1/2 through 1-1/4 extend through corresponding slots in both rim and backplate and are securely staked in place. On sizes 1-3/8 and larger, the ends of the blades are fully riveted to rim and backplate. In addition, full width wheels sizes 1 and larger, and smaller sizes over 6000 ft./min. tip speed, are peripherally reinforced as standard. This construction produces an inherently strong and ridged wheel. Wheel hubs may be external for mounting on motor shaft with external accessibility to setscrews, or they may be internal. Hub bores are furnished with standard keyways two setscrews 120° apart. Tapped wheel puller holed are available as an extra feature. All uni-combustion wheels are precision balanced, statically and dynamically.



HOUSINGS

Uni-combustion fan housings are symmetrical so that they are interchangeable for either clockwise or counterclockwise rotation. Both housing sides are made with an opening large enough to install or remove the wheel. Eight holes around each opening permit the housing to be rotated to any of eight discharges. Flanged inlet and outlet connections are available. Standard housings for sizes 1/2 and 5/8 are one piece cast iron with a round outlet. Standard

housings for size 3/4 and larger are fabricated from sheet steel and have rectangular outlets. Housing sides are secured to the scroll by a seam welded joint. Cast iron housings are also available for sizes 3/4, 1 and 1-1/4. Inlet rings with or without vortex control are cast iron for sizes 3/4 through 1-1/4. Sizes 1-3/8 through 2 are supplied with fabricated or spun steel cones, with or without vortex inlet damper control. Inlet screens are available for all sizes.



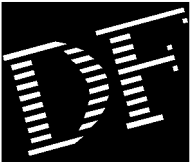

COMPLETE FANS IN 4 VARIATIONS

COMPLETE FAN ASSEMBLIES

Complete Uni-Combustion fans are built in arrangement (Arr.) 4 with the fan wheel mounted on the motor shaft. Two variations of this arrangement are furnished. In Arr. 4U, available in sizes 1/2 through 1-1/4 for smaller motor frames, the motor is mounted on an adjustable support attached to the drive sideplate. Housing is supported by legs on both inlet and drive side. Arr. 4E, available in sizes 3/4

through 2, has a box type motor base supported from the foundation. Housing is overhung from the motor base except in size 1-3/8 and larger which have inlet sideplate legs for additional housing support. Complete fans are given a running inspection check when motors are mounted at the factory. This procedure insures smooth, trouble-free operation on the job.



Arrangement 4U
With Vortex Inlet Damper



Arrangement 4E
With Vortex Inlet Damper



Arrangement 4-Duplex
With Vortex Inlet Dampers



Arrangement 4-Pancake
With Inlet Screen And
Flanged Outlet

WHEEL DIMENSIONS

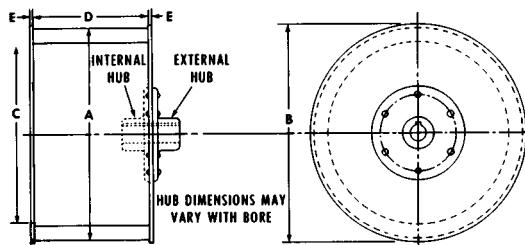

WHEELS CAN BE FURNISHED WITH EITHER INTERNAL OR EXTERNAL HUB

WHEEL SIZE	AVAILABLE WHEEL WIDTHS											E	WEIGHT LBS.*	
	A	B	C	D1 (FULL)	D2	D3	D4	D5	D6	D7	D8			
1/2	6½	6¾	5⅝	3		2			1½				1/16	3
5/8	8½	8¼	7⅛	3¾		2½			27/8	1½	1		5/64	4
9"	9	9¼	7¾	4½	3½	3	2½	2	1¾	1½	1		5/64	5
3/4	9¾	10	8½	4½	3½	3	2½	2	1¾	1½	1		5/64	8
7/8	11¾	11¾	9¾	6	5	4	3	3		2	2		5/64	10
1	13	13¼	11¼	6	5	4	3	3		2	2		5/64	12
1½	14¾	15	12½	7½		5							5/64	17
1¼	16¼	16¾	14¼	7½		5							5/64	20
1¾	17¾	18½	15½	8¼									5/64	30
1¾ SPEC.	19½	19¾	17¾	8¼									7/64	39
1½	19½	19¾	17¾	9									7/64	41
1¾	22¾	23¾	20	10½									1/8	57
2	26	26½	22½	12									1/8	88
2¼	29¼	30	25¾	13½									5/32	100
2½	32½	33¼	28¾	15									5/32	130

BLADE WIDTHS SHOWN IN BOLD ARE STANDARD

* WEIGHTS ARE FOR FULL WIDTH WHEELS HAVING STANDARD HUBS

FULL WIDTH CAPACITIES

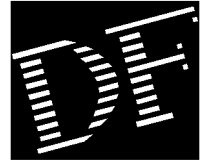

FAN SIZE	RPM	Tip Speed Ft./min.	1/2" SP		1" SP		1-1/2" SP		2" SP		2-1/2" SP		3" SP		3-1/2" SP		4" SP		5" SP		6" SP		7" SP		8" SP		9" SP		10" SP	
			CFM	BHP	CFM	BHP	CFM	BHP	CFM	BHP	CFM	BHP	CFM	BHP	CFM	BHP	CFM	BHP	CFM	BHP	CFM	BHP	CFM	BHP	CFM	BHP	CFM	BHP	CFM	BHP
1/2	3450	5865	1118	1.18	1088	1.17	1023	1.11	955	1.04	887	0.96	818	0.88	731	0.78														
	1750	2975	485	0.13	280	0.07																								
5/8	3450	7348	2221	3.35	2210	3.7	2150	3.58	2070	3.45	1990	3.33	1900	3.19	1810	3.04	1720	2.89	1550	2.56	1150	1.82								
	1750	3727	1028	0.42	877	0.37	642	0.27																						
	1160	2471	550	0.1																										
3/4	3450	8797	4160	12.43	4130	11.43	4020	11.18	3910	10.9	3800	10.63	3690	10.37	3580	10.1	3470	9.83	3230	9.19	3000	8.56	2780	7.88	2550	7.23	2280	6.39		
	1750	4462	1960	1.5	1770	1.29	1570	1.15	1320	0.96																				
	1160	2958	1125	0.37	788	0.24																								
7/8	3450	10281	7360	25.63	7240	25.15	7125	24.76	6970	24.25	6870	23.78	6710	23.29	6640	22.6	6490	22.38	6258	21.45	5990	20.35	5800	22.7	5500	21.4	52.6	20.1	4930	18.9
	1750	5215	3550	3.17	3330	2.93	3070	2.67	2810	2.43	2510	2.17	2190	1.93																
	1160	3457	2150	0.84	1740	0.67	1230	0.47																						
1	1750	5967	4860	6.59	4600	6.21	4340	5.8	4050	5.4	3770	5	3500	4.6	3200	4.3	2860	3.65												
	1160	3956	3000	1.78	2598	1.5	2140	1.21																						
	850	2898	1935	0.62	1290	0.38																								
1 1/8	1750	6702	7760	11.48	7440	10.98	7120	10.49	6800	9.95	6480	9.39	6150	8.89	5800	8.34	5450	7.82	4680	6.7										
	1160	4443	4875	3.15	4398	2.8	3860	2.45	3340	2.11	2475	1.58																		
	850	3255	3275	1.13	2550	0.86																								
1 1/4	1750	7437	9850	20.05	9600	19.52	9330	18.8	9060	18.13	8800	17.44	8530	16.73	8250	16.06	7970	15.4	73.7	14	6730	12.56	5980	10.98						
	1160	4930	6325	5.64	5920	5.16	5510	4.71	5060	4.25	4610	3.8	4060	3.29																
	850	3612	4375	2.07	3810	1.75	3150	1.38																						
1 3/8	1750	8190	13005	30.04	12740	29.2	12405	28.40	12070	27.5	11770	26.75	11480	26	11170	25.25	10880	24.5	10250	22.9	9620	21.35	8980	19.8	8270	18.3	6750	14.8		
	1160	5429	8370	8.45	7890	7.89	7440	7.42	7000	6.92	6520	6.38	6030	5.88	5500	5.34	4050	3.91												
	850	3978	5810	3.14	5112	2.77	4590	2.41	3750	1.96																				
1 3/8 Special	1750	8925																			9370	25.6	8900	24.2	8380	22.7	7840	21		
1 1/2	1750	8925	16700	47.1	16350	45.9	16050	44.9	15760	43.9	15380	43.1	15040	41.9	14700	40.65	14370	39.7	13690	37.35	12980	35	12200	32.55	11370	30	10450	27.3	9400	24.3
	1160	5916	10790	13.29	10300	12.6	9800	11.95	9270	11.17	8740	10.4	8160	9.6	7550	8.77	6900	7.91												
	850	4335	7600	5	6900	4.48	6190	3.94	5370	3.35	3800	2.31																		
1 3/4	1160	6902	16900	24.33	16300	23.4	15700	22.5	15000	21.35	14380	20.25	13600	19	13000	18	12360	16.9	10950	16.25										
	850	5057	11975	9.24	11170	8.55	10275	7.78	9375	6.99	8340	6.12	6675	4.78																
2	1160	7900	25400	47.95	24600	46.6	24000	45.2	23200	43.5	22600	42.3	21800	40.7	21000	39	20300	37.5	18700	34.3	17100	31								
	850	5788	18200	18.35	17200	17.25	16275	16.2	15250	15.03	14200	13.9	13100	12.61	11875	11.25														

NOTES TO CAPACITY TABLE

Size 1/2 and 5/8 have cast iron housings. Size 3/4 through 2 have steel housings.

Contact factory for performance information on size 3/4, 1, and 1-1/4 cast iron housings.

All capacities are based on standard density (.075# per cu. ft. - 70°F. - 29.92" Hg Bar).

Capacities are based on fans equipped with Vortex inlet damper in the wide open position (except size 1/2 and 5/8 which are not available with Vortex dampers).

For capacities with partially closed Vortex dampers, refer to your nearest DF Fan sales office. Capacities shown in bold require special construction for complete assemblies - standard dimensions and pricing does not apply.

To obtain approximate performance of narrow width fans, multiply the CFM and BHP from the table above, by the % of the full width wheel. The % width is the ratio of blade width used to the dimension D1 shown in the table on page 4.

Example: Given a size 1 wheel having a blade with D3, find the performance when operating at 1160 RPM with 1" SP.

From the table on page 4, D1=6" and D3=4".

$$\% \text{ width} = \frac{D3}{D1} = \frac{4}{6} = .667$$

The CFM = 2598 x .667 = 1730; and BHP = 1.5 x .667 = 1.0

A 9" wheel diameter wheel (intermediate between size 5/8 and 3/4) is available. No housing, inlets, vortex dampers are available for this size.

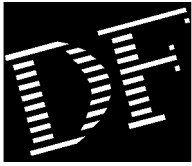

HOUSING & COMPLETE FAN DIMENSIONS

CAST IRON HOUSINGS

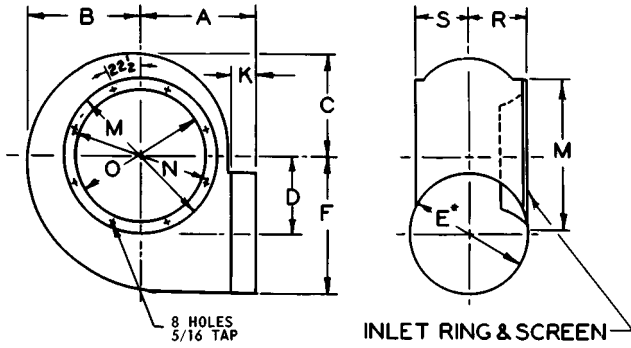

UNI-COMBUSTION CAST IRON HOUSINGS

FAN SIZE	A	B	C	D	E*	F	K	M	N	O	R	S
1/2	6 1/8	6	5 3/8	3 1/16	6	6 7/8	1 1/4	8 3/8	7 1/2	6 3/8	3	2 3/4
5/8	7 1/4	7 7/16	6 5/8	4 3/8	7 1/2	8 9/16	1 1/4	10 3/8	9 1/2	8 3/4	3 3/8	3 3/8
3/4 - Half	7 1/4	7 1/4	6 7/8	6 1/16	4 3/8	8 3/8	1 1/4	10 3/8	9 1/2	8 3/4	2 3/8	2 3/8
3/4	8 3/8	8 3/8	7 1/8	5 1/2	9	10 9/16	1 1/4	12 1/2	11 1/2	10 3/4	4 1/4	4
1	10 3/4	11 1/8	10 9/16	7 1/16	12	13 1/4	1 1/2	15 5/8	14 3/8	13 1/2	5 1/16	5 3/8
1 1/4	13 1/8	14 1/16	13	9 3/8	15	16 1/16	1 1/2	19 3/4	18 3/8	17 3/4	6 1/16	6 3/8

* Outside Inlet

Arrangement 4U - CAST IRON HOUSINGS

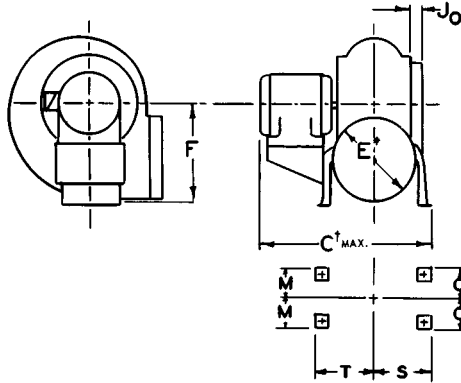

FAN SIZE	F	JO				M	O	E*	R	S	T	U	V
		NO VORTEX Arr. 4U	Arr. 4E	WITH VORTEX Arr. 4U	Arr. 4E								
1/2	7 1/4	1 7/8	—	—	—	2 7/8	3 3/8	6	—	5 1/16	5 5/16	—	—
5/8	8 3/4	1 7/8	—	—	—	3 3/4	4 1/4	7 1/2	—	6 1/16	6 1/16	—	—
3/4 - Half	8 3/4	1 7/8	—	—	—	3 3/4	4 1/4	4 3/8	—	5 1/16	5 1/16	—	—
3/4	10 1/2	1 1/2	1 1/2	3 3/8	3 3/8	4 1/2	5 1/4	9	5 1/2	7 3/8	7 3/8	13	8 3/4
1	14	1 7/8	1 7/8	3 1/2	3 1/2	6	7	12	7 3/8	9 1/16	9 1/16	13	10 1/2
1 1/4	17 1/2	2 1/2	2 1/2	4 1/4	4 1/4	1 1/2	9	15	8 3/8	11 1/8	11 1/8	16 3/4	10 1/2

* Outlet Dimensions - Outside

STEEL HOUSINGS

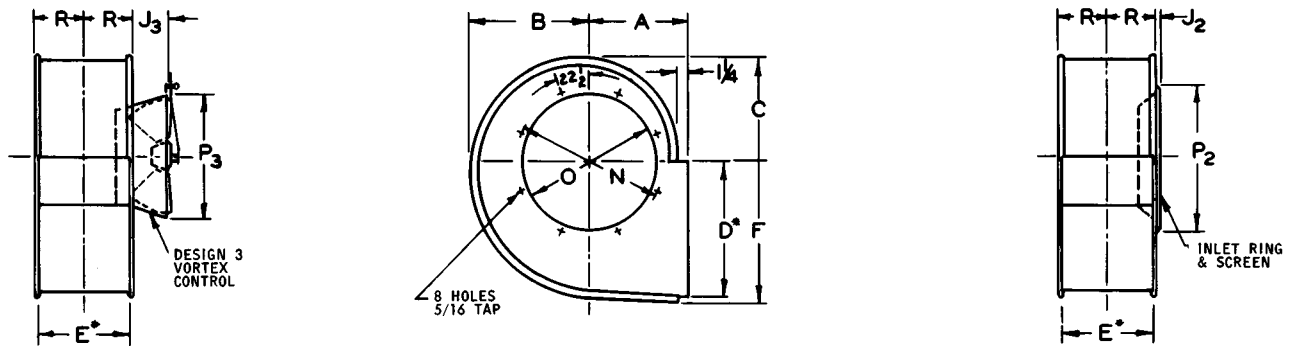

UNI-COMBUSTION STEEL HOUSINGS

FAN SIZE	A	B	C	D*	F	O	N	P ₂	P ₃	J ₂	J ₃	FULL WIDTH		2/3 WIDTH		1/2 WIDTH		1/3 WIDTH	
												E*	R	E*	R	E*	R	E*	R
3/4	8 3/8	8 3/8	7 7/8	9 3/4	10 9/16	10 3/4	11 1/2	12 1/4	11 1/4	1/8	3 1/8	7 1/2	3 3/8	6	3 3/8	5 1/4	2 3/4	4 1/2	2 3/8
7/8	9 3/8	10 1/4	9 1/16	11 3/8	11 7/8	12	13	13 3/8	12 1/4	1/8	3 3/8	8 3/4	4 1/2	6 3/4	3 1/2	5 3/4	3	4 3/4	2 1/2
1	10 9/16	11 1/16	10 9/16	13	13 1/2	13 1/2	14 3/8	15 1/2	14	3/16	3 1/2	10	5 1/8	8	4 3/8	7	3 3/8	6	3 3/8
1 1/8	11 3/16	12 5/16	11 7/16	15 3/8	15 1/8	15 3/8	16 7/16	17 3/8	16	3/16	3 3/8	11 1/4	5 3/4	8 3/4	4 1/2	—	—	—	—
1 1/4	12 3/16	14 7/16	12 1/16	16 1/8	16 3/8	17 1/8	18 3/8	19 3/8	18	3/16	4 1/4	12 3/8	6 3/8	9 7/8	5 1/8	—	—	—	—
1 3/8	13 1/4	15 3/4	13 3/8	17 3/8	18 3/16	18 1/2	19 1/2	20 1/2	19 1/2	3/16	4 1/16	13 3/8	6 15/16	—	—	—	—	—	—
1 1/2	14 1/4	17 3/8	15 1/16	19 1/4	19 3/4	20 1/4	21 1/4	22 3/4	21 3/8	3/16	5 1/4	14 7/8	7 3/8	—	—	—	—	—	—
1 3/4	16 1/4	19 7/8	17 1/16	22 1/2	23 1/16	23 3/4	24 3/4	23 3/4	23 3/4	2 1/16	2 7/8	17 1/4	8 7/8	—	—	—	—	—	—
2	18 1/4	22 3/8	19 3/16	25 3/8	26 7/16	27	28	27	27	2 3/8	2 13/16	19 3/4	10 1/8	—	—	—	—	—	—

* OUTSIDE OUTLET *HOUSINGS NOT AVAILABLE FOR THE 9" WHEEL* ALL DIMENSIONS IN INCHES. DIMENSIONS NOT TO BE USED FOR CONSTRUCTION UNLESS CERTIFIED.

ARRANGEMENT 4U

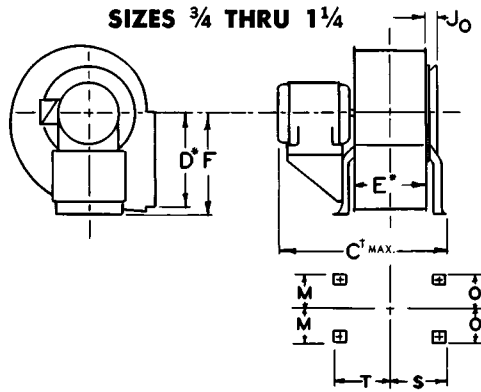

ARRANGEMENT 4E

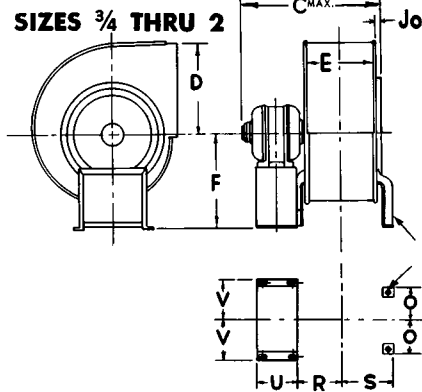

UC ASSEMBLY - STEEL HOUSINGS

FAN SIZE	D*	F	JO				M	O	FULL WIDTH					2/3 WIDTH				1/2 WIDTH				1/3 WIDTH				
			NO VORTEX Arr. 4U		WITH VORTEX Arr. 4E				E*	R	S	T	U	V	E*	R	S	T	E*	R	S	T	E*	R	S	T
3/4	9 3/4	10 1/2	1 1/2	—	3 1/2	3 1/2	4 1/2	5 1/4	7 1/2	5 1/4	7 1/2	7 3/8	13	8 3/4	6	4 1/2	6 3/8	6 3/8	5 1/2	4 1/8	6	6 1/4	4 1/2	3 3/4	5 3/8	5 7/8
7/8	11 3/8	12 1/4	1 7/8	—	3 3/8	3 3/8	5 1/2	6	8 3/4	6 3/8	8 3/8	13	9 1/4	6 3/4	5 3/8	7 3/8	7 3/8	5 3/4	4 7/8	7 1/8	7 3/8	4 3/4	4 3/8	6 3/8	6 7/8	
1	13	14	2	—	3 1/2	3 1/2	6	7	10	7	9 1/2	13	10 1/2	8	6	8 1/2	8 1/2	7	5 1/2	8	8	6	5	7 1/2	7 1/2	
1 1/8	14 3/8	15 3/4	2	—	4	4	6 1/2	7 1/2	11 1/4	7 1/2	10 3/8	16 3/4	10 3/8	8 3/4	6 3/8	8 3/8	8 3/8	—	—	—	—	—	—	—	—	
1 1/4	16 1/8	17 1/2	2 1/2	—	4 1/4	4 1/4	7 1/2	9	12 3/8	8 3/8	11 1/8	17 1/8	11 1/8	9 1/8	6 1/2	10 1/8	10 1/8	—	—	—	—	—	—	—	—	
1 3/8	17 3/8	19	—	2 3/4	4 1 1/8	4 1 1/8	—	9 1/2	13 3/8	8 1 3/8	12 3/8	—	—	—	—	—	—	—	—	—	—	—	—	—	—	
1 1/2	19 1/4	20 1/2	—	2 1/2	5 1/4	5 1/4	—	7 1/2	14 7/8	10	11 1/8	—	—	—	—	—	—	—	—	—	—	—	—	—	—	
1 3/4	22 1/2	23 1/2	—	2 3/4	—	—	—	8 3/4	17 3/8	11 1/8	12 3/8	—	—	—	—	—	—	—	—	—	—	—	—	—	—	
2	25 3/4	26 3/4	—	2 1 1/8	—	—	—	10	19 3/4	12 3/8	14 3/8	—	—	—	—	—	—	—	—	—	—	—	—	—	—	

* OUTLET DIMENSIONS - OUTSIDE

ARR. 4E NEMA MOTOR FRAME SIZES WITH VORTEX CONTROL

FAN SIZE	56T		143T		145T		182T		184T		213T		215T		254T		256T		284T		286T		324T		326T		FAN WGT LESS MOTOR
	ODP	TEFC	ODP	TEFC	ODP	TEFC	ODP	TEFC	ODP	TEFC	ODP	TEFC	ODP	TEFC	ODP	TEFC	ODP	TEFC	ODP	TEFC	ODP	TEFC	ODP	TEFC	ODP	TEFC	
1/2	—	—	—	—	—	—	—	—	—	—	—	—	—	—	—	—	—	—	—	—	—	—	—	—	—	—	—
3/4	19 1/16	19 1/16	20	20 1/2	20 3/4	21 1/4	21 3/8	23 3/8	22 3/8	24 3/8	25 3/8	27 3/8	26 1/16	29 1/8	—	—	—	—	—	—	—	—	—	—	—	—	73LBS
7/8	21 3/4	21 3/4	21 7/8	22 7/8	22 3/4	23 3/8	23 3/4	25 1/2	24 3/4	26 1/2	27 1/4	29 1/2	28 3/16	31 1/16	—	—	—	—	—	—	—	—	—	—	—	—	90LBS
1	22 1/2	22 1/2	23 1/2	23 1/2	23 3/4	24 1/4	24 3/4	26 1/2	25 3/4	27 1/2	27 3/4	30 1/2	29 1/8	32 1/8	—	—	—	—	—	—	—	—	—	—	—	—	106LBS
1 1/8	23 1/8	23 1/8	24 1/8	24 1/8	25 1/8	25 3/8	25 3/4	27 1/2	26 3/4	28 1/2	29 1/4	31 1/2	30 3/16	33	34 3/16	36 1/2	36	38 3/16	—	—	—	—	—	—	—	—	123LBS
1 1/4	26	26	26 3/16	26 1/16	26 1 1/8	27 1/8	27 3/8	29 1/8	28 3/8	30 1/8	30 3/8	32 3/8	32 3/8	34 3/8	35 1/2	37 1/16	37 1/4	39 3/16	—	—	—	—	—	—	—	—	196LBS
1 3/8	—	—	—	—	—	—	28 1/16	30 1/16	29 1/16	31 1/16	31 3/16	33 1/16	33 3/16	35 3/16	36 1/2	38 3/16	38 3/16	40 3/16	40 3/16	43 3/16	41 3/16	45 1/16	45 1/16	—	—	—	255LBS
1 1/2	—	—	—	—	—	—	—	—	—	—	—	33 1/16	35 1/16	35	37 1/4	37 3/8	39 1/16	39 1/8	41 1/16	41 3/16	44 1/16	45 1/16	44 3/16	47 1/16	45 3/4	49	313LBS
1 3/4	—	—	—	—	—	—	—	—	—	—	—	—	—	—	39 3/16	41 7/16	41 3/16	43 3/16	43 3/16	46 3/16	44 7/16	48 3/16	46 3/16	49 3/16	47 7/16	51 1/16	397LBS
2	—	—	—	—	—	—	—	—	—	—	—	—	—	—	44 1/16	46 7/16	45 3/16	48 3/16	47 1/16	51 3/16	49 7/16	52 1/16	50 3/16	54 3/16	52 1/16	55 1/16	506LBS
Apx Motor Wgt.	37	37	47	47	38	52	65	85	80	100	105	150	125	175	200	260	225	290	295	390	325	440	400	555	450	625	< ADD

ARR. 4E FANS

FAN SIZE	C MAX.	NEMA FRAME MIN.	NEMA FRAME MAX.
1/2	18	48	56
3/4	19	48	56
7/8	23	56	145T
1	29	56	184T
1 1/8	30	143T	184T
1 1/4	35	143T	215T
1 1/2	39	143T	215T

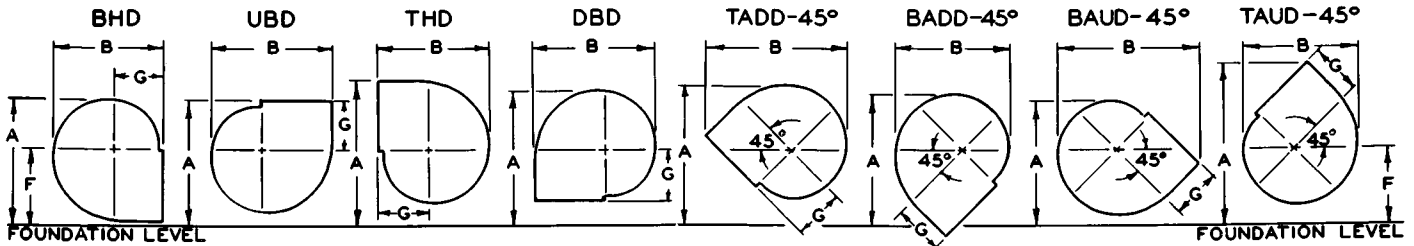

FAN SIZE	BHD		UBD		THD		DBD		TADD 45°		BADD 45°		BAUD 45°		TAUD 45°		G
	A	B	A	B	A	B	A	B	A	B	A	B	A	B			
1/2	12 3/8	12 1/2	13 3/8	12 1/4	14 1/8	12 1/2	13 1/4	12 1/4	13 3/8	14 1/8	12 1/8	11 3/8	12 1/4	14 1/8	16 3/8	11 3/8	6 1/8
5/8	15 3/8	14 1/16	16	15 3/8	17 3/8	14 1/16	16 3/8	15 3/8	16 1/16	18 1/8	15 3/8	14 1/8	15	18	19 3/8	14 3/8	7 1/8
3/4	18 3/8	17	18 3/8	18 3/8	20 3/8	17	19 3/8	18 3/8	19 3/8	21	18 3/8	16 3/8	17 3/8	21	23 3/8	16 3/8	8 3/8
7/8	21 3/8	19 3/8	21 3/8	20 1/16	24 1/8	19 3/8	22 1/2	20 1/16	23 1/8	24 1/8	21 1/8	19 3/8	20 3/4	24 1/8	25 3/8	19 3/8	9 3/8
1	24 3/8	21 7/8	24 3/8	23 1/16	27 1/2	21 7/8	25 1/16	23 1/16	26 3/8	27 3/8	25	22	23 3/4	27 3/8	30 3/8	22	10 3/8
1 1/8	27 3/8	24 1/8	26 1/16	26 3/8	30 7/8	24 1/8	28 1/16	26 3/8	29 3/8	30 3/8	27 3/16	24 3/8	26 7/16	30 3/8	33 1/16	24 3/8	11 3/8
1 1/4	30 3/8	26 3/8	29 1/16	29 3/8	34 1/8	26 3/8	31 3/16	29 3/8	32 1/16	33 1/8	31 1/16	27 3/8	29 3/16	33 1/8	37 1/16	27 3/8	12 3/8
1 3/8	32 3/8	29	32 1/4	32 1/16	37 3/8	29	34 3/4	32 1/16	35 1/16	36 3/8	33 1/16	29 3/8	31 1/16	36 3/8	40 1/16	29 3/8	13 3/8
1 1/2	35 3/8	31 3/8	34 3/4	34 1/16	40 1/4	31 3/8	37 3/8	34 1/16	38 1/16	40	36 3/8	32 1/4	34 3/16	40	44 3/8	32 1/4	14 3/8
1 3/4	40 1/16	36 1/8	39 3/4	40 3/8	46 3/8	36 1/8	43 3/8	40 3/8	44 3/8	46 1/4	42 3/8	37 3/8	39 3/4	46 1/4	51 1/8	37 3/8	16 1/4
2	46 3/8	40 3/8	45	46 1/4	52 3/8	40 3/8	49 3/8	46 1/4	50 3/8	52 3/8	48	42 3/8	45 3/8	52 3/8	57 1/8	42 3/8	18 1/4

UNI-COMBUSTION FANS

Complete fan assemblies and parts for supplying combustion air for oil, gas and coal firing. Built in 11 basic sizes with capacities from 200 to 24,000 CFM at static pressures to 10" W.G. with vortex inlet damper control for improved volume regulation and power saving.
Specify Bulletin 18001.



Arrangement 4E Assembly



UC Wheel -
Internal Hub



UC Wheel -
External Hub



Multiple Width Wheels

FUME HOOD FANS

Complete Fan Assemblies including fans, housings, drives and covers for exhausting fumes from industrial and institutional laboratory hoods or other corrosive fume exhaust systems. Completely packaged, ready-to-run in four basic sizes with capacities from 250 to 6300 CFM at static pressures to 5" W.G. Available with Forward Curved or Backward Inclined fan wheels.
Specify Bulletin 26001.



Fume Hood Fan Assembly

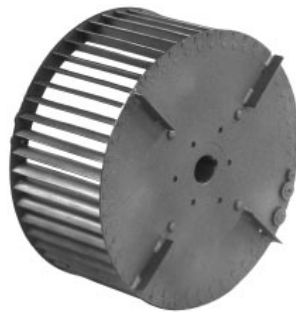

Fume Hood Wheels With
Pressure Bars

UNITARY, SINGLE AND DUPLEX FANS

Complete fan assemblies, parts or kits designed for heavy duty applications, including ovens, dryers, air conditioning units, heaters, coolers, condensers and air curtains. Fully riveted or staked fan wheels with welded housings. Capacities from 150 to 88,000 CFM at static pressures to 8" W.G. and temperatures to 1000° F.
Specify Bulletin 6131.

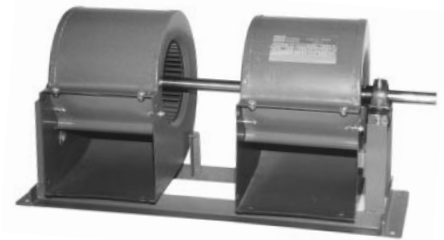

DFB Duplex Fan Assembly



DF Wheel

Wheel Diameters 6-1/2" through 32-1/2"

Custom Fan Assemblies & Kits

Individual Wheels, Housings, and Component
Parts Available

Aluminum, Stainless Steel, Monel, and Galvanized
Steel Construction